



250 Staunton Turnpike, Parkersburg, WV 26104

# 8800 Series ("HVHZ") Vinyl Horizontal Sliding Window "IMPACT"

### GENERAL NOTES

1. This product has been evaluated and is in compliance with the 8th Edition (2023) Florida Building Code (FBC) structural requirements including the "High Velocity Hurricane Zone" (HVHZ).
2. Product anchors shall be as listed and spaced as shown on details. Anchor embedment to base material shall be beyond wall dressing or stucco.
3. When used in the "HVHZ", this product complies with Section 1626 of the FBC and does not require an impact resistant covering.
4. For 2x stud framing construction, anchoring of these units shall be the same as that shown for 2x buck masonry construction.
5. Site conditions that deviate from the details of this drawing require further engineering analysis by a licensed engineer or registered architect.
6. This product meets the water infiltration requirements for the "HVHZ".

TABLE OF CONTENTS	
SHEET#	DESCRIPTION
1	Typical elevations, design pressures and general notes
2	Horizontal cross sections
3	Vertical cross sections
4	Buck and frame anchoring
5	Components
6	Bill of materials and glazing details

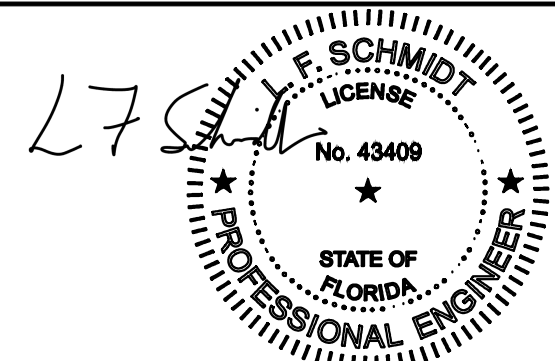

This item has been digitally signed and sealed by L. F. Schmidt, P.E. on the date adjacent to the seal. Printed copies of this document are not considered signed and sealed and the signature must be verified on any electronic copies.

THIS PRODUCT APPROVAL IS VALID ONLY FOR THE STATE OF FLORIDA

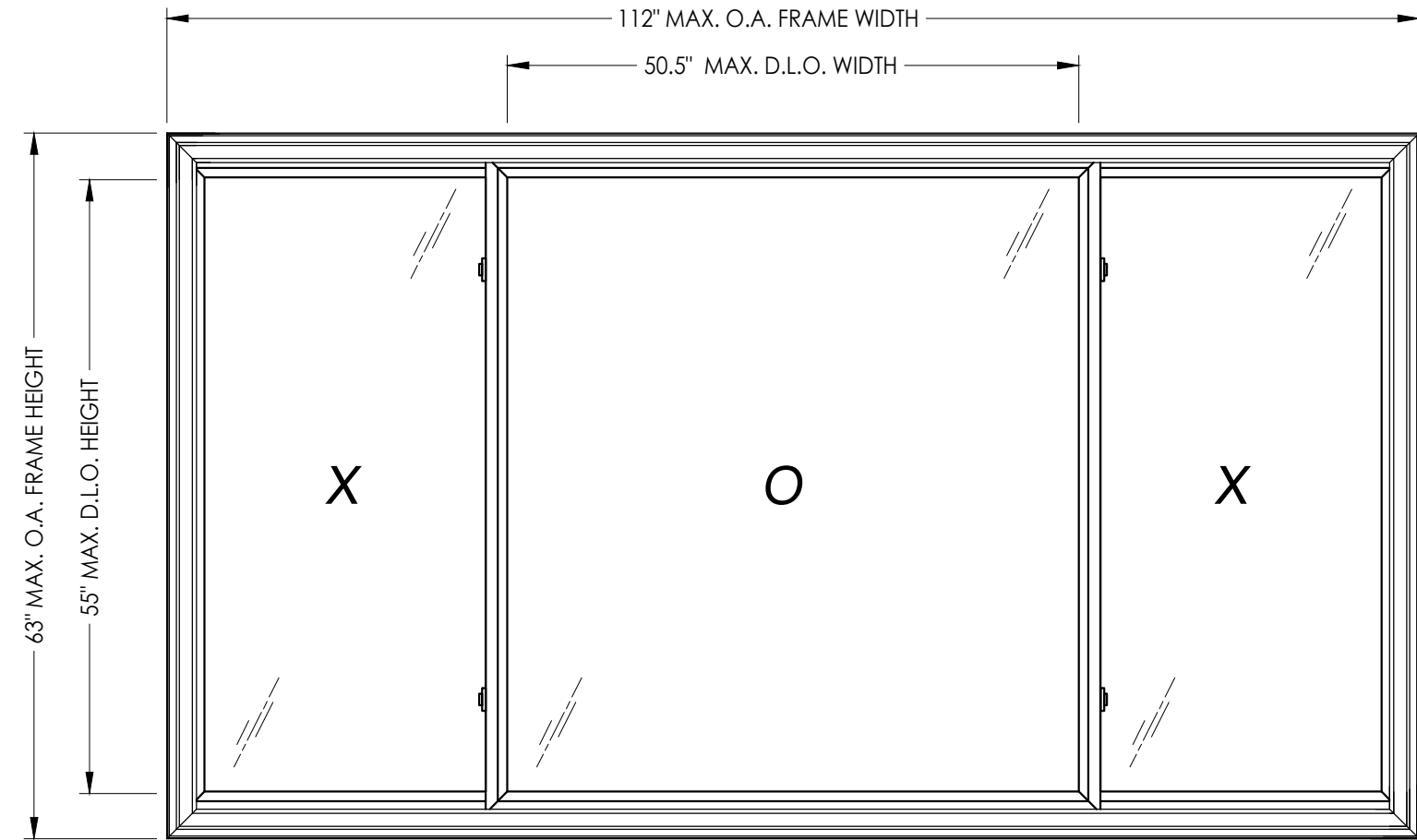

XOX SHOWN  
XXX ALSO APPROVED

MAX. FRAME DIMENSION	MAX. D.L.O. DIMENSION	GLASS TYPE	DESIGN PRESSURE (PSF)	
			POSITIVE	NEGATIVE
112.0" X 63.0"	50.5" X 55.0"	G1	+50.0	-55.0
		G2	+60.0	-65.0

Documents Prepared By:  
Lyndon F. Schmidt  
P.E. No. 43409

8800 SERIES

PART OR ASSEMBLY:  
TYPICAL ELEVATION, DESIGN PRESSURES & GENERAL NOTES

NO.	DATE	REVISIONS
5	7/06/23	UPDATE TO 8TH ED. (2023) FBC
4	7/06/20	UPDATE TO 7TH ED. (2020) FBC
3	1/30/19	REVISE ANCHORING
2	6/01/17	UPDATE TO 6TH ED. (2017) FBC
1	1/28/15	UPDATE TO 5TH ED. (2014) FBC

DATE: 4/08/13  
SCALE: N.T.S.  
DWG. BY: JK  
CHK. BY: LFS  
DRAWING NO.: FL-16092.8  
SHEET 1 OF 6

R.W. BUILDING CONSULTANTS, INC.  
P.O. Box 230, Valrico, FL 33595  
Phone No.: 813.659.9197  
FBPE Registry No. 9813

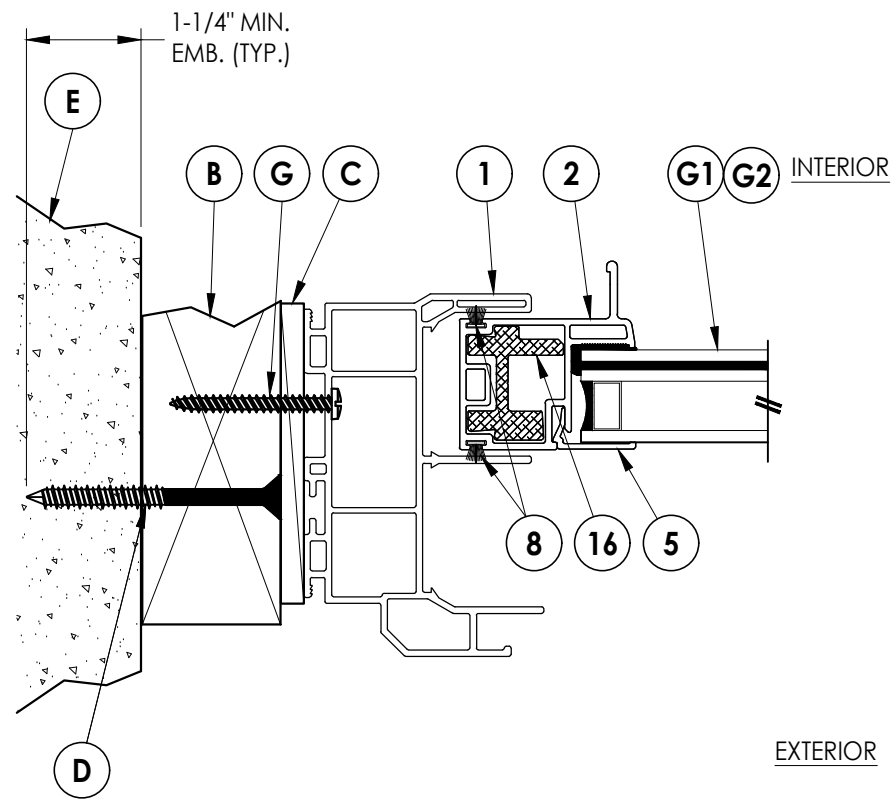
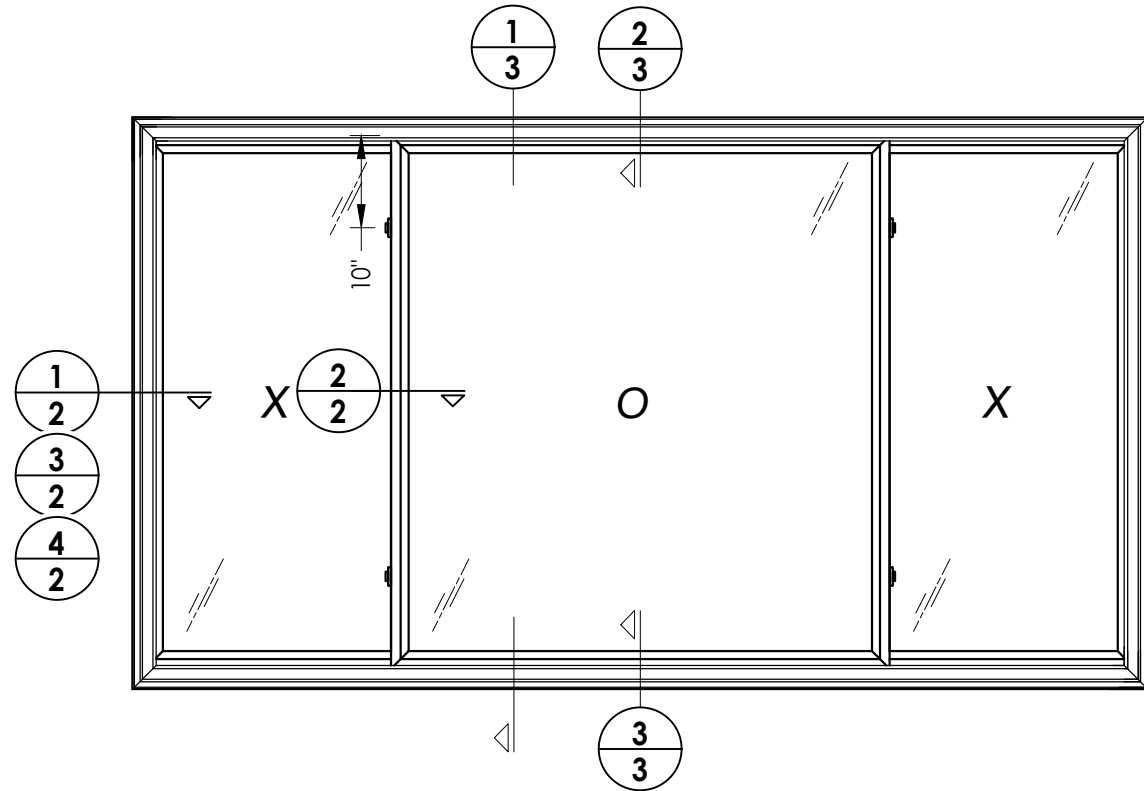

**1** HORIZONTAL CROSS SECTION  
**2** Shown w/ 2X buck

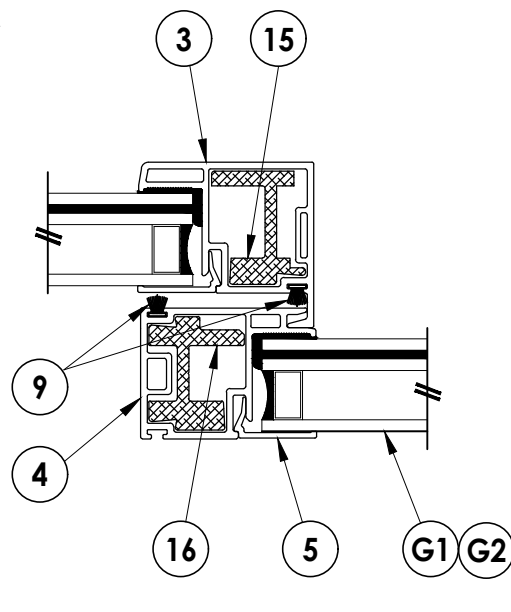

**2** HORIZONTAL CROSS SECTION  
**2**

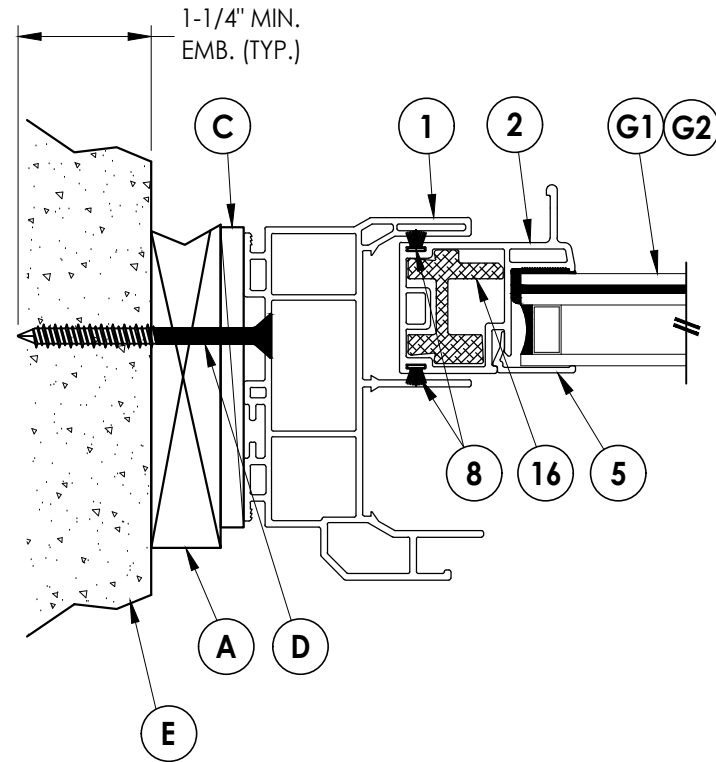

**4** HORIZONTAL CROSS SECTION  
**2** Shown w/ 1X buck

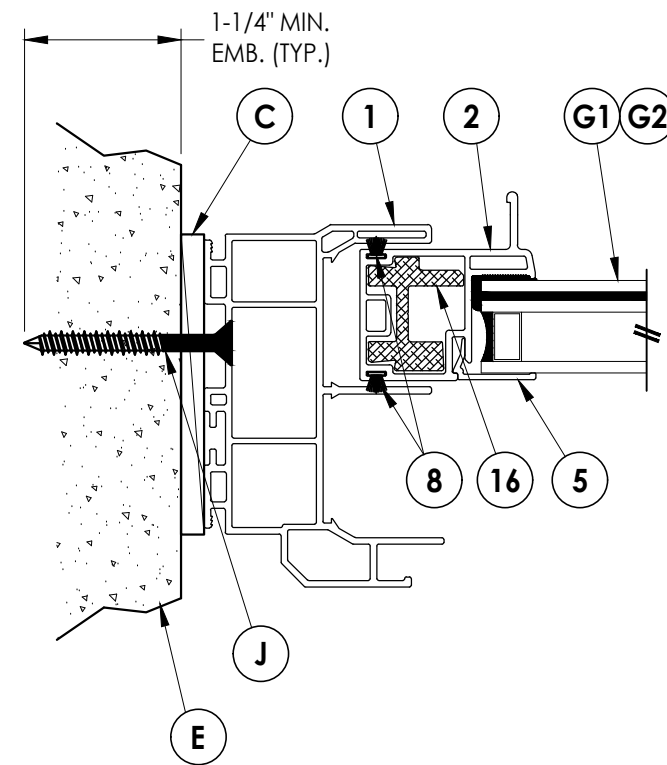

**3** HORIZONTAL CROSS SECTION  
**2** Shown direct to masonry

Documents Prepared By:  
 Lyndon F. Schmidt  
 P.E. No. 43409

**RW** BUILDING CONSULTANTS, INC.  
 P.O. Box 230, Valrico, FL 33595  
 Phone No.: 813.659.9197  
 FBPE Registry No. 9813

PRODUCT: 8800 SERIES

PART OR ASSEMBLY:  
 HORIZONTAL  
 CROSS SECTIONS

NO.	DATE	REVISIONS
5	7/06/23	UPDATE TO 8TH ED. (2023) FBC LFS
4	7/06/20	UPDATE TO 7TH ED. (2020) FBC LFS
3	1/30/19	REVISE ANCHORING MT
2	6/01/17	UPDATE TO 6TH ED. (2017) FBC LFS
1	1/28/15	UPDATE TO 5TH ED. (2014) FBC JK

DATE: 4/08/13

SCALE: N.T.S.

DWG. BY: JK

CHK. BY: LFS

DRAWING NO.:

FL-16092.8

SHEET 2 OF 6

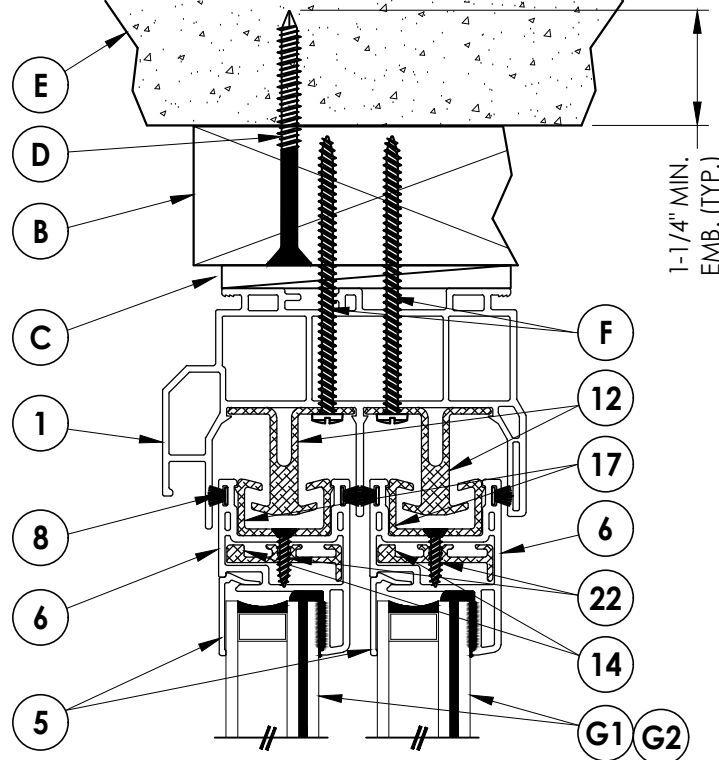

EXTERIOR INTERIOR

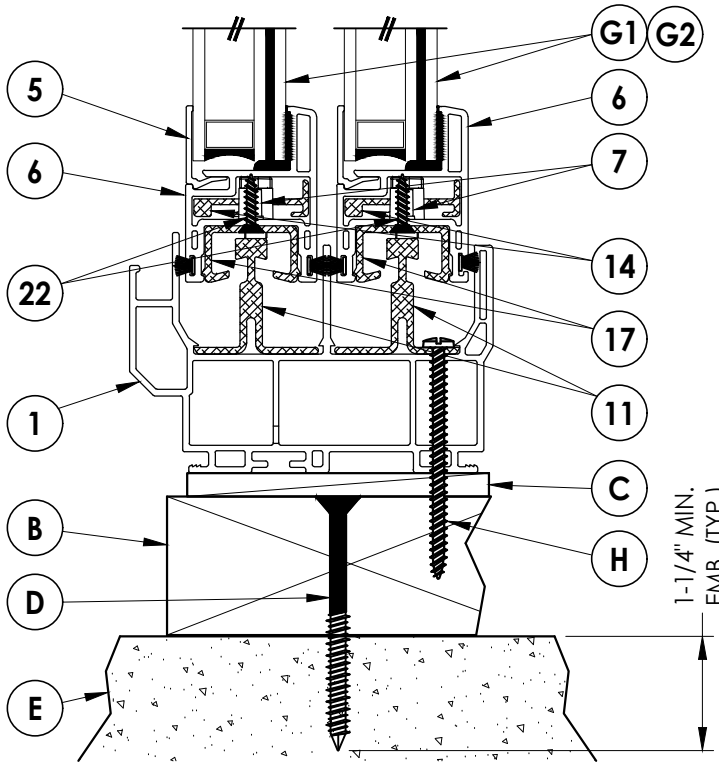

**1** VERTICAL CROSS SECTION  
**3** Shown w/ 2X buck

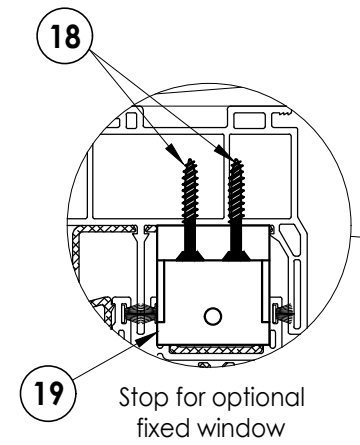

19 Stop for optional fixed window

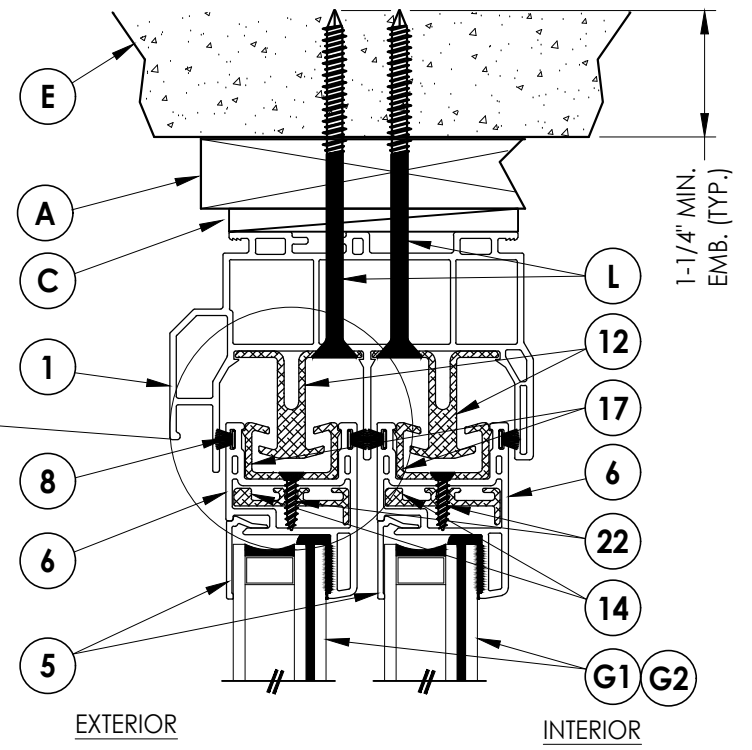

EXTERIOR INTERIOR

**2** VERTICAL CROSS SECTION  
**3** Shown w/ 1X buck

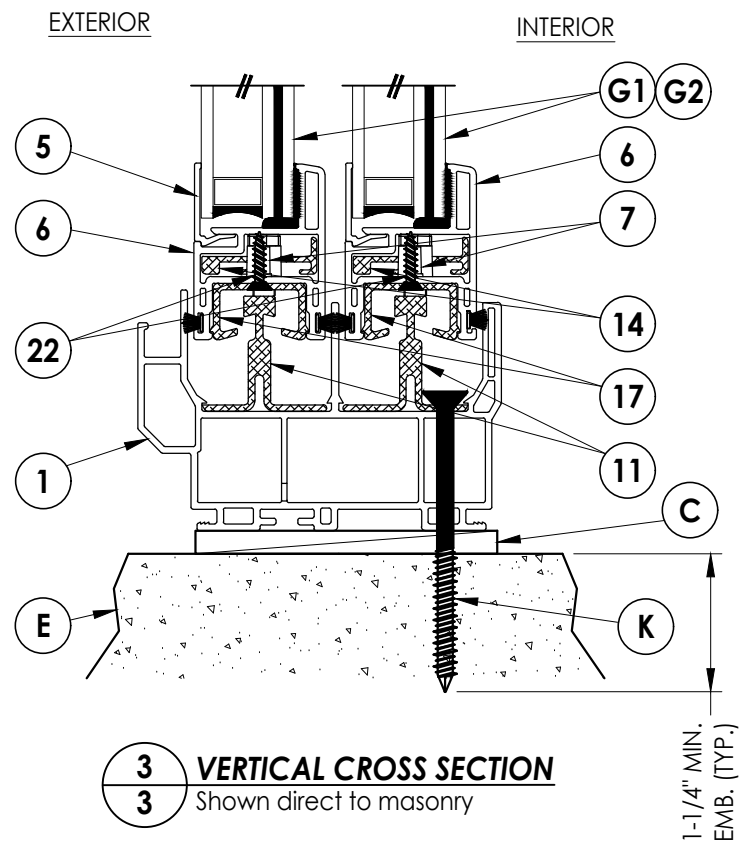

**3** VERTICAL CROSS SECTION  
**3** Shown direct to masonry

Documents Prepared By:  
Lyndon F. Schmidt  
P.E. No. 43409

**RW** BUILDING CONSULTANTS, INC.  
P.O. Box 230, Vairico, FL 33595  
Phone No.: 813.659.9197  
FBPE Registry No. 9813

PRODUCT: 8800 SERIES

PART OR ASSEMBLY:  
VERTICAL CROSS SECTIONS

NO.	DATE	REVISIONS	BY
5	7/06/23	UPDATE TO 8TH ED. (2023)	FBC LFS
4	7/06/20	UPDATE TO 7TH ED. (2020)	FBC LFS
3	1/30/19	REVISE ANCHORING	MT
2	6/01/17	UPDATE TO 6TH ED. (2017)	FBC LFS
1	1/28/15	UPDATE TO 5TH ED. (2014)	FBC JK

DATE: 4/08/13  
SCALE: N.T.S.  
DWG. BY: JK  
CHK. BY: LFS  
DRAWING NO.: FL-16092.8  
SHEET 3 OF 6

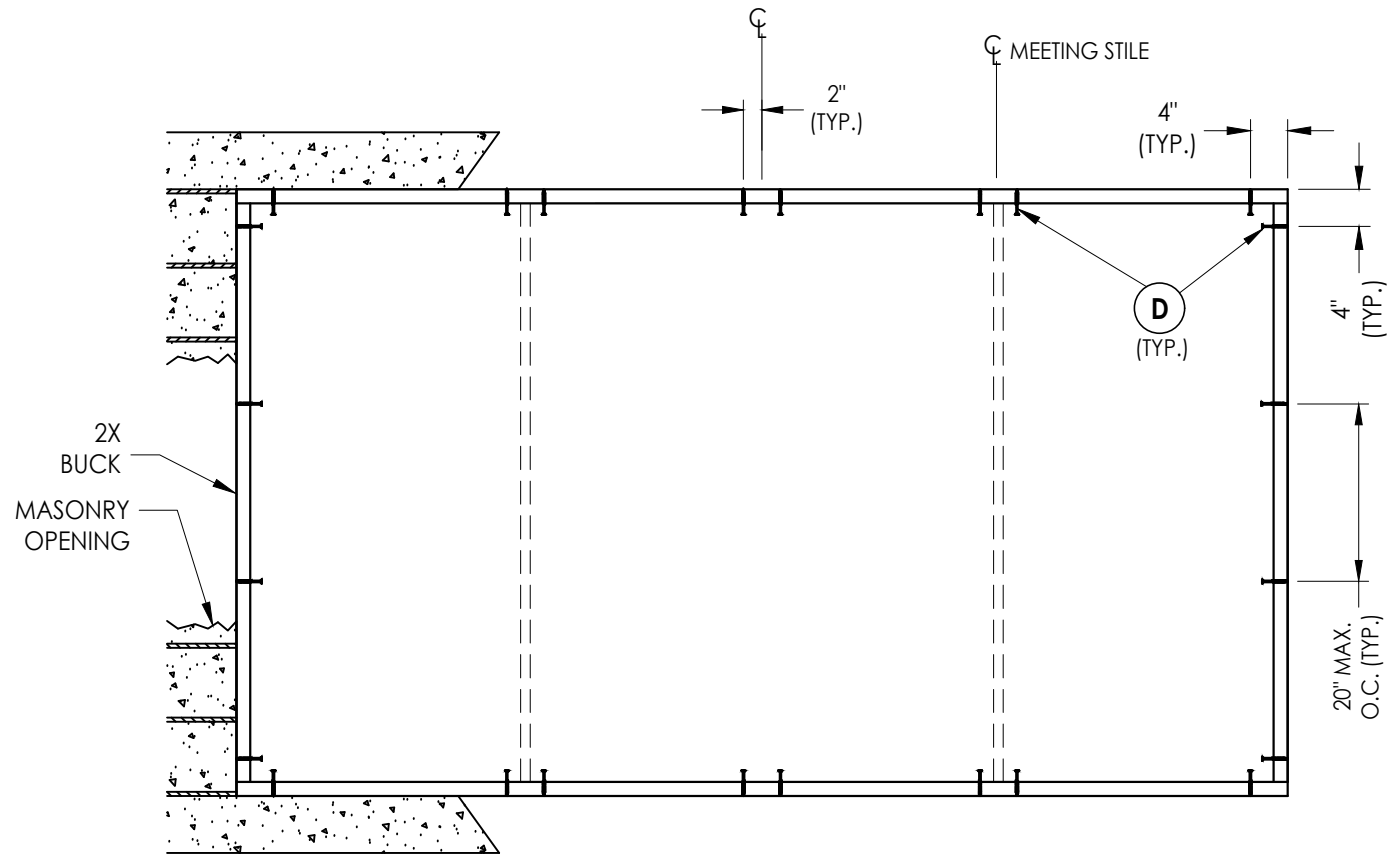

**BUCK ANCHORING**

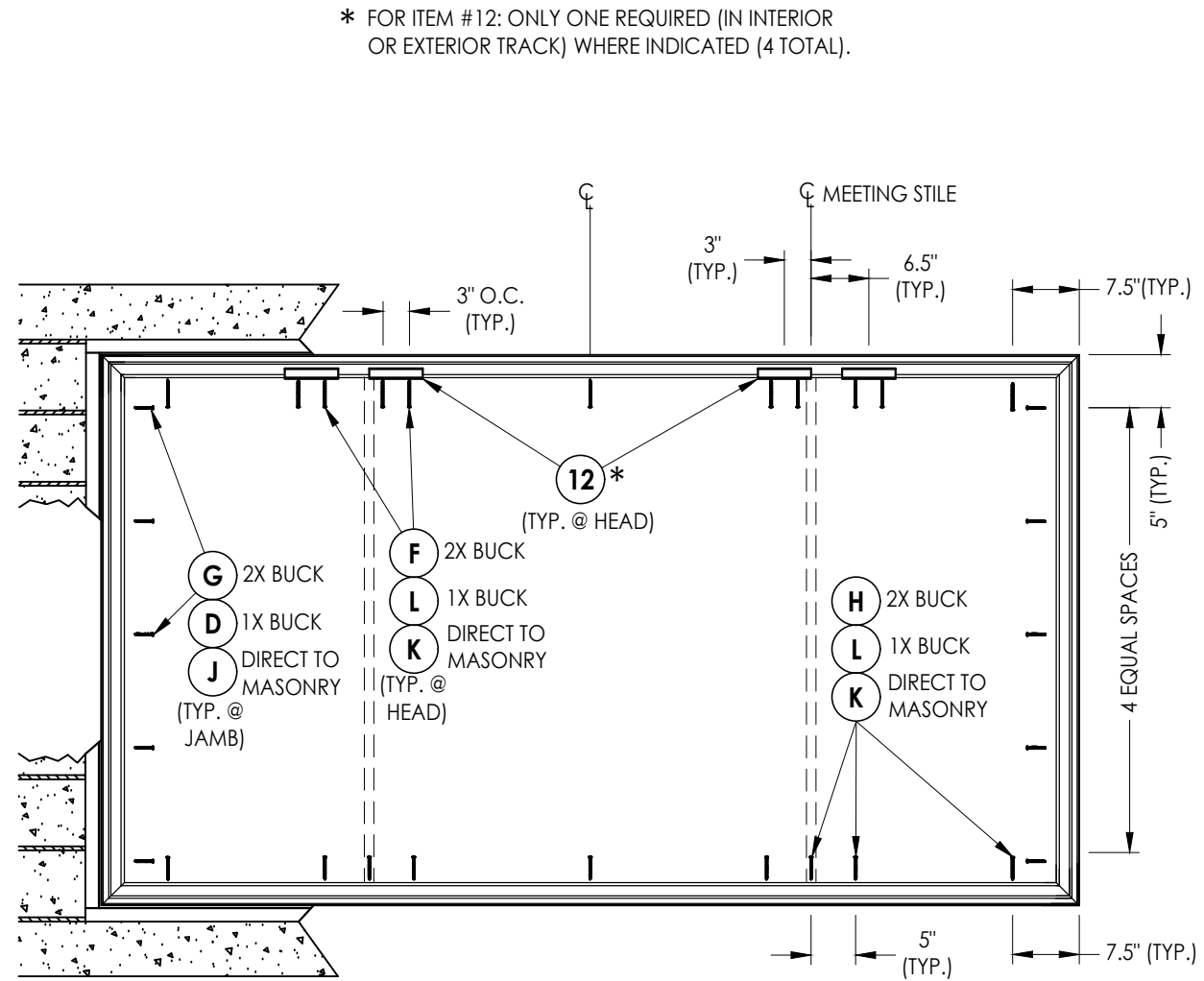

**FRAME ANCHORING**

\* FOR ITEM #12: ONLY ONE REQUIRED (IN INTERIOR OR EXTERIOR TRACK) WHERE INDICATED (4 TOTAL).

**CONCRETE ANCHOR NOTES:**

1. Concrete anchor locations at the corners may be adjusted to maintain the min. edge distance to mortar joints.
2. Concrete anchor locations noted as "MAX. ON CENTER" must be adjusted to maintain the min. edge distance to mortar joints, additional concrete anchors may be required to ensure the "MAX. ON CENTER" dimension are not exceeded.
3. Concrete anchor table:

ANCHOR TYPE	ANCHOR SIZE	MIN. EMBEDMENT	MIN. CLEARANCE TO MASONRY EDGE	MIN. CLEARANCE TO ADJACENT ANCHOR
ITW TAPCON®	1/4"	1-1/4"	2"	4"
DeWALT ULTRACON®	1/4"	1-1/4"	2-1/2"	3"
HILTI KWIK-CON II+	1/4"	1-1/4"	2-1/2"	3"

**WOOD SCREW INSTALLATION NOTES:**

1. Maintain a minimum 5/8" edge distance, 1" end distance, & 1" o.c. spacing of wood screws to prevent the splitting of wood.

Documents Prepared By:  
Lyndon F. Schmidt  
P.E. No. 43409

**RW** BUILDING CONSULTANTS, INC.  
P.O. Box 230, Vairico, FL 33595  
Phone No.: 813.659.9197  
FBPE Registry No. 9813

PRODUCT: 8800 SERIES

PART OR ASSEMBLY:  
BUCK & FRAME ANCHORING

NO.	DATE	REVISIONS
5	7/06/23	UPDATE TO 8TH ED. (2023) FBC LFS
4	7/06/20	UPDATE TO 7TH ED. (2020) FBC LFS
3	1/30/19	REVISE ANCHORING MT
2	6/01/17	UPDATE TO 6TH ED. (2017) FBC LFS
1	1/28/15	UPDATE TO 5TH ED. (2014) FBC JK

DATE: 4/08/13

SCALE: N.T.S.

DWG. BY: JK

CHK. BY: LFS

DRAWING NO.:

FL-16092.8

SHEET 4 OF 6

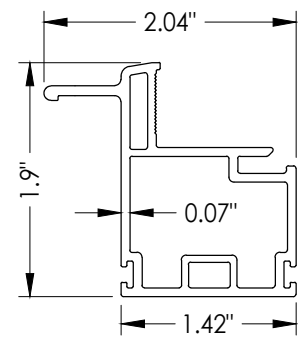

**2 SLIDER PULL STILE**

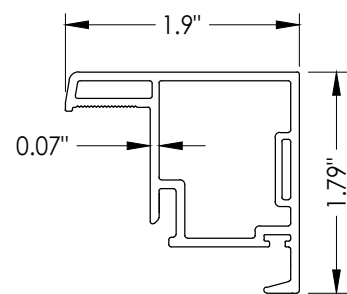

**3 LOCK STILE**

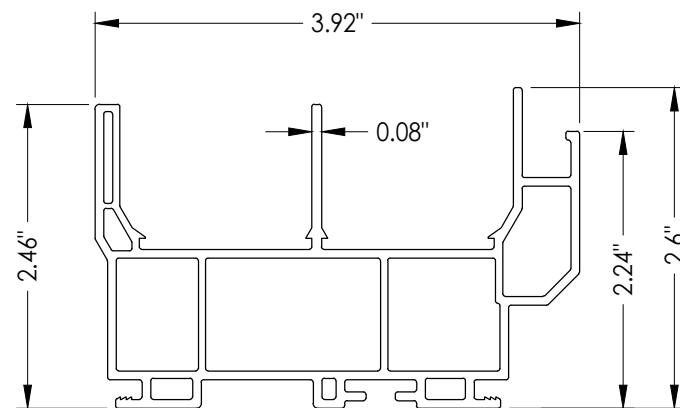

**1 FRAME**

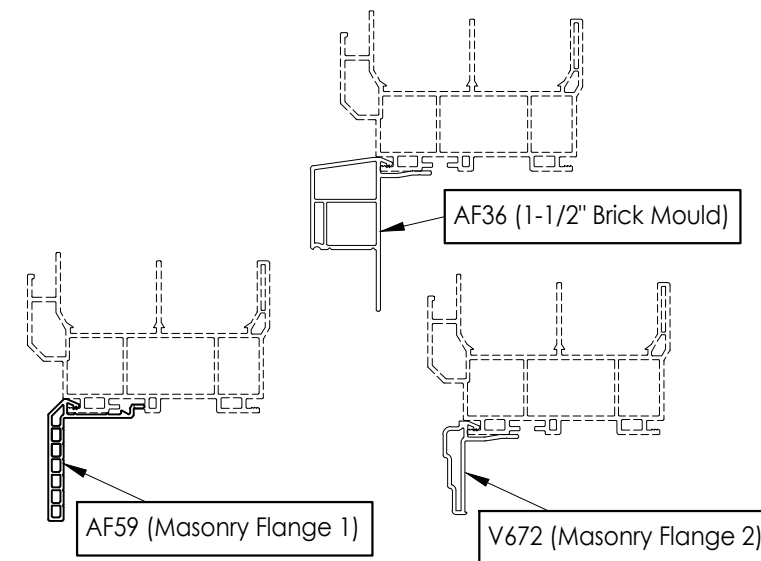

**OPTIONAL COSMETIC FLANGES**

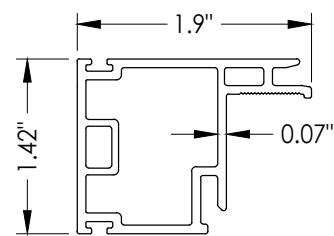

**4 KEEPER STILE**

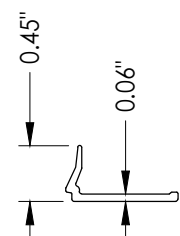

**5 GLAZING BEAD**

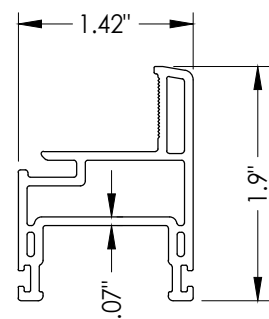

**6 SLIDER COMMON RAIL**

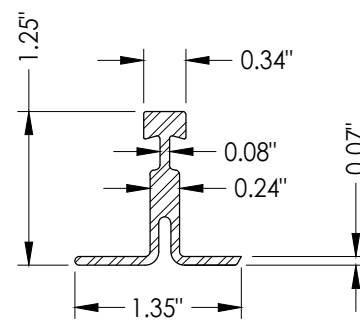

**11 SILL TRACK**  
Full width

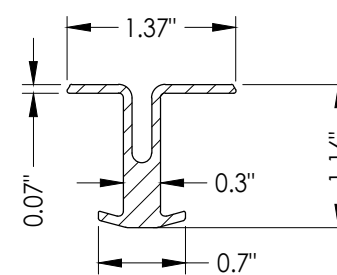

**12 HEAD TRACK**  
6" Long

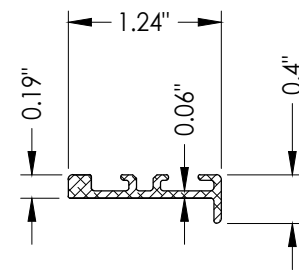

**14 REINFORCEMENT**  
Common Rail

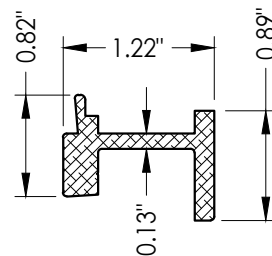

**15 REINFORCEMENT**  
Lock Stile

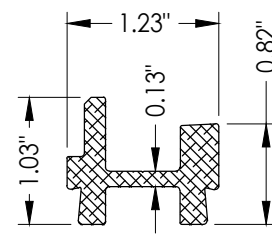

**16 REINFORCEMENT**  
Keeper and Pull Stile

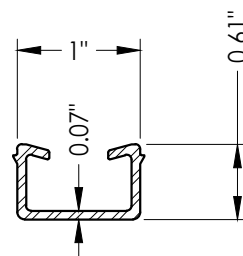

**17 SLIDER SASH RETAINING CLIP**

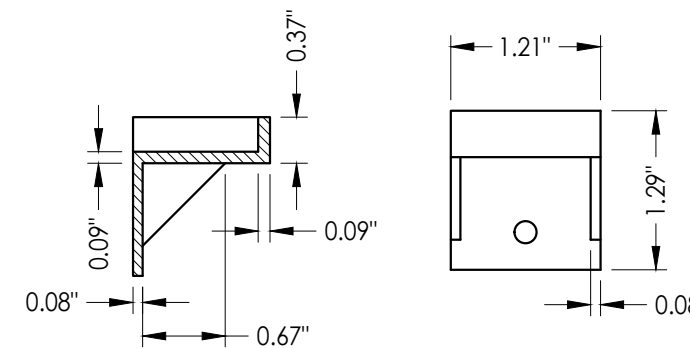

**19 FLANKER STOP**

Documents Prepared By:  
Lyndon F. Schmidt  
P.E. No. 43409

**RW** BUILDING CONSULTANTS, INC.  
P.O. Box 230, Vairico, FL 33595  
Phone No.: 813.659.9197  
FBPE Registry No. 9813

PRODUCT: 8800 SERIES

NO.	DATE	REVISIONS
5	7/06/23	UPDATE TO 8TH ED. (2023) FBC LFS
4	7/06/20	UPDATE TO 7TH ED. (2020) FBC LFS
3	1/30/19	REVISE ANCHORING MT
2	6/01/17	UPDATE TO 6TH ED. (2017) FBC LFS
1	1/28/15	UPDATE TO 5TH ED. (2014) FBC JK

DATE: 4/08/13

SCALE: N.T.S.

DWG. BY: JK

CHK. BY: LFS

DRAWING NO.:

FL-16092.8

SHEET 5 OF 6

G:\2023 FBC DRAWINGS\Wincore Window Company\FL-16092.8.dwg

BILL OF MATERIALS		
ITEM #	DESCRIPTION	MATERIAL
A	1X BUCK (SG >= 0.55)	WOOD
B	2X BUCK (SG >= 0.55)	WOOD
C	1/4" MAX. SHIM SPACE	-
D	1/4" X 2-3/4" PFH DeWALT OR ITW CONCRETE SCREW	STEEL
E	MASONRY - 3,000 PSI MIN. CONCRETE CONFORMING TO ACI 301 OR HOLLOW BLOCK CONFORMING TO ASTM C90	CONCRETE
F	#10 X 3" PPH WOOD SCREW (1-3/8" MIN. EMBEDMENT)	STEEL
G	#10 X 1-3/4" PPH WOOD SCREW (1-1/8" MIN. EMBEDMENT)	STEEL
H	#10 X 2-1/2" PPH WOOD SCREW (7/8" MIN. EMBEDMENT)	STEEL
J	1/4" X 2-1/4" ITW CONCRETE SCREW	STEEL
K	1/4" X 3-1/4" ITW CONCRETE SCREW	STEEL
L	1/4" X 3-3/4" ITW CONCRETE SCREW	STEEL
1	FRAME*	PVC
2	SLIDER PULL STILE*	PVC
3	LOCK STILE*	PVC
4	KEEPER STILE*	PVC
5	GLAZING BEAD*	PVC
6	SLIDER COMMON RAIL*	PVC
7	BALL BEARING ROLLER	-
8	WEATHERSTRIP (0.230")	-
9	WEATHERSTRIP (0.380")	-
11	SILL TRACK	ALUM
12	HEAD TRACK	ALUM
14	SLIDE RAIL REINFORCEMENT (6063-T6 ALUM)	ALUM
15	REINFORCEMENT (6005-T5 ALUM)	ALUM
16	REINFORCEMENT (6005-T5 ALUM)	ALUM
17	SLIDER SASH RETAINING CLIP	ALUM
18	#8 X 1" PFH SMS	STEEL
19	FLANKER STOP	NYLON
22	#8 X 5/8" (#6 head) PFH SMS	STEEL

\* THE APPROVED WHITE RIGID PVC EXTERIOR EXTRUSIONS FOR WINDOWS ARE TO BE PRODUCED BY EXTRUDERS LICENSEES IN "AAMA CERTIFICATION PROGRAMS FOR RIGID PVC EXTRUSIONS".

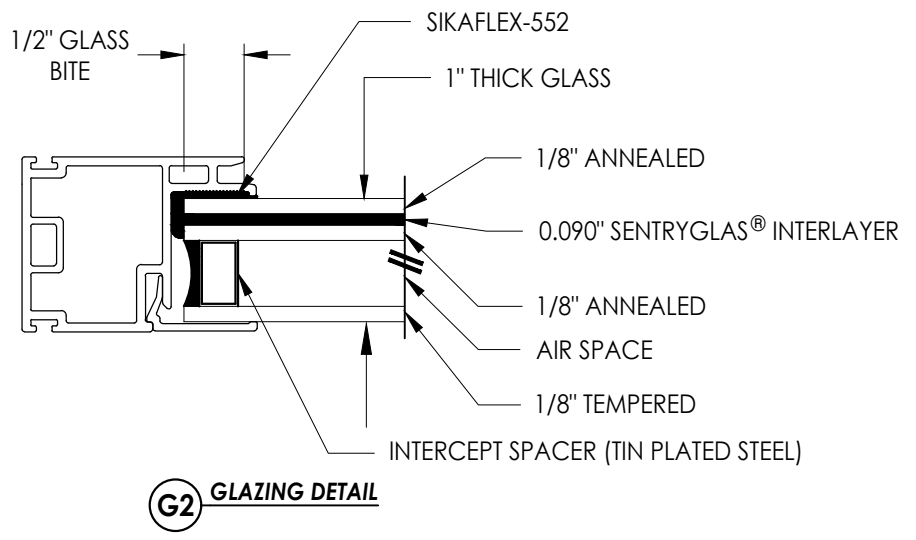
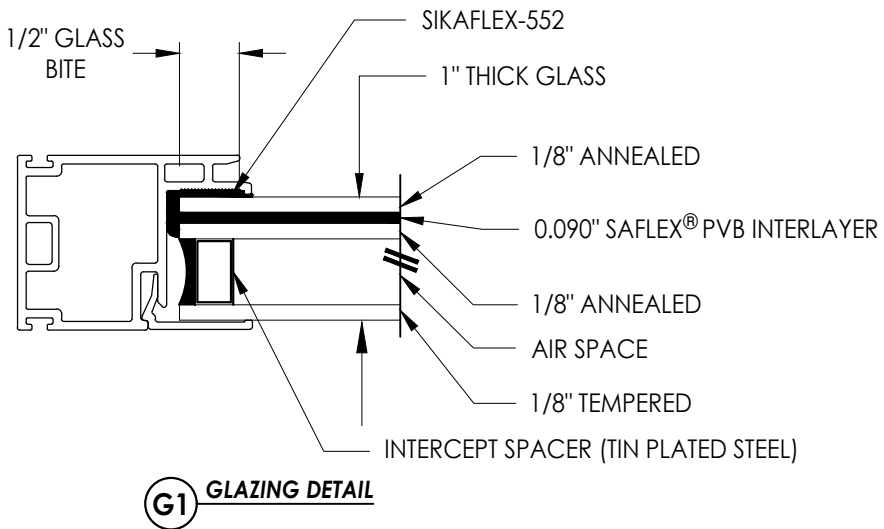

NOTE: GLAZING > 36" WIDE REQUIRES TWO (2) SETTING BLOCKS CONFORMING TO FBC SECTION 2411.3.3.1.

Documents Prepared By:  
Lyndon F. Schmidt  
P.E. No. 43409

**RW** BUILDING CONSULTANTS, INC.  
P.O. Box 230, Valrico, FL 33595  
Phone No.: 813.659.9197  
FBPE Registry No. 9813

PRODUCT: 8800 SERIES

PART OR ASSEMBLY: BILL OF MATERIALS & GLAZING DETAILS

NO.	DATE	REVISIONS
5	7/06/23	UPDATE TO 8TH ED. (2023) FBC
4	7/06/20	UPDATE TO 7TH ED. (2020) FBC
3	1/30/19	REVISE ANCHORING
2	6/01/17	UPDATE TO 6TH ED. (2017) FBC
1	1/28/15	UPDATE TO 5TH ED. (2014) FBC

DATE: 4/08/13

SCALE: N.T.S.

DWG. BY: JK

CHK. BY: LFS

DRAWING NO.: FL-16092.8

SHEET 6 OF 6

© 2013 R.W. BUILDING CONSULTANTS INC.